



Master BulkSlide

SOLIDS FLOW METER



CUSTOM TEK
INDUSTRIAL WEIGHING SOLUTIONS

customtek.co.uk

Master BulkSlide

Solids Flow Meter

The Master BulkSlide is a solids flow meter that measures with accuracy from $\pm 0,5$ percent. It can be used for most solid bulk products that are free flowing and non-sticky. The BulkSlide calculates the product flow and total by measuring the force of the bulk product as it contacts the curved plate within the BulkSlide assembly.

The BulkSlide offers many advantages, including nearly zero maintenance and very low power consumption. With a stable zero point, compact design and many communications options to transfer data to a PLC or PC, the BulkSlide is adaptive for many environments.

Dynamic Weighing Instrumentation

Rice Lake's 882D is durable, compact and engineered to provide accurate data in a wide range of environments.

Designed with advanced programming capabilities and an I/O option, the 882D can be customized to manage product dosing and metering. Communicating with other equipment or a PLC is made possible with the 882D's fieldbus interface.

The 882D's IP66 stainless steel enclosure protects the instrument in harsh environments. Whether weighing for process control or a truck, barge or rail loadout application, you can rely on the 882D for durable performance in every setting.



The Master BulkSlide pairs with all types of material feeder options providing accuracy even with variable conveyor or feeder outputs.

Slide Construction	Application
Stainless Steel	Powder materials
Hardox® 400	Semi-abrasive products, grain, cement
Polyurethane	Sticky materials, coffee beans, cocoa beans
Ceramic Coated	Abrasive products, corn soy, sunflower

SLIDE AT OUTLET

Master BulkSlide installed with a silo slide outlet.

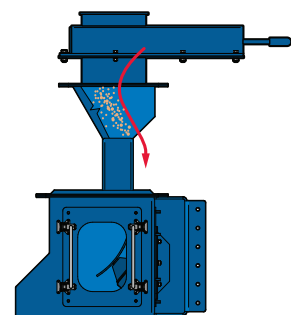

SCREW CONVEYOR

Master BulkSlide installed after a rotary valve.

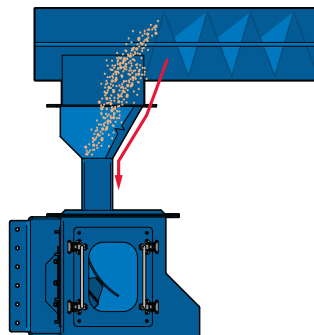

ROTARY VALVE

Master BulkSlide installed after a screw conveyor.

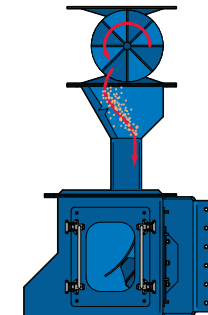

FREE FALL

Master BulkSlide installed below free falling material.

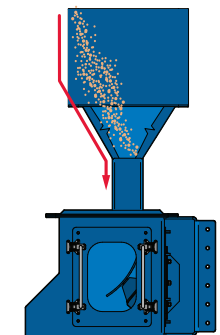



Master BulkSlide

SOLIDS FLOW METER

Standard Features

- Pre-calibrated
- Accuracy from $\pm 0,5\%$
- Independent from density
- Communication Option: 4-20mA or Fieldbus

Applications:

- Grain/Feed
- Cement/Construction Materials
- Wood
- Recycling
- Food and Chemical

Specifications

Housing Construction:	Painted or Stainless Steel
Slide Construction:	Carbon Steel, Stainless Steel, Hardox® or Ceramic
Capacity:	Up to 600m3/hour
Temperature:	-40 to 75 C optional 160 C -40 to 167 F optional 320 F
Approvals:	ATEX and FM approved load cells can be provided
System Accuracy:	From $\pm 0,5\%$
Warranty:	One-year limited warranty



Metric					
Type	Min. flow rate [m3/h]	Max. flow rate [m3/h]	Max. particle size [mm]	Dimensions: L x W x H [mm]	Weight of BulkSlide [kg]
Model BF006	1	6	25	280 x 280 x 503	23
Model BF012	5	12	20	320 x 350 x 625	30
Model BF024	10	24	30	350 x 450 x 625	40
Model BF050	20	50	40	350 x 750 x 625	55
Model BF060	24	60	40	500 x 450 x 798	65
Model BF100	40	100	50	515 x 515 x 900	70
Model BF200	80	200	50	515 x 515 x 900	75
Model BF400	160	400	50	670 x 670 x 1,210	85
Model BF600	250	600	60	670 x 670 x 1,210	95

Imperial					
Type	Min. flow rate [ft3/h]	Max. flow rate [ft3/h]	Max. particle size [in]	Dimensions: L x W x H [in]	Weight of BulkSlide [lb]
Model BF006	15	212	1	11 x 11 x 19.80	28.6
Model BF012	177	424	1.2	12.6 x 13.8 x 24.61	66.1
Model BF024	318	848	1.2	13.8 x 17.7 x 24.61	66.1
Model BF050	706	1,766	1.6	13.8 x 29.5 x 24.61	110.2
Model BF060	840	2,100	1.6	19.7 x 17.7 x 31.42	143.3
Model BF100	1,413	3,531	2.0	20.3 x 20.3 x 35.43	154.3
Model BF200	2,825	7,063	2.0	20.3 x 20.3 x 35.43	165.3
Model BF400	5,650	14,126	2.0	26.4 x 26.4 x 47.64	187.4
Model BF600	8,829	22,189	2.4	26.4 x 26.4 x 47.64	209.4

SALES AND TECHNICAL ASSISTANCE

CUSTOM TEK
INDUSTRIAL WEIGHING SOLUTIONS

Custom Tek Ltd
Building 321, Bedford Technology Park
Thurleigh Beds, MK44 2YA · Tel No. 01234 780144

customtek.co.uk